

CARGO POD - MAINTENANCE PRACTICES

1. General

- A. A cargo pod with a 80-cubic-foot and a 700 pounds capacity can be installed on Model 208 airplanes. Screws attach the pod to the bottom of the fuselage. The pod (and doors) have a nomex inner housing, a layer of kevlar and an outer layer of fiberglass. Aluminum bulkheads divide the pod into three compartments. Each compartment has a door to load cargo installed on the left side of the pod. The doors have hinges on the bottom and latches on the top. The doors lock in the closed position when latch handles are turned to a horizontal position.
- B. A cargo pod with a 111.5-cubic-foot and a 1090 pounds capacity can be installed on Model 208B airplanes. Screws attach the pod to the bottom of the fuselage. The pod (and doors) are fabricated with a nomex inner housing, a layer of kevlar and an outer layer of fiberglass. Aluminum bulkheads divide the pod into four compartments. Each compartment has a door to load cargo installed on the left side of the pod. The doors have hinges on the bottom and latches on the top. The doors lock in the closed position when latch handles are turned to a horizontal position.

2. Cargo Pod Removal/Installation

- A. Remove the Cargo Pod (Refer to Figure 201).
 - (1) Make sure that the cargo pod is empty.
 - (2) Remove the TKS anti-ice fluid tank. Refer to Chapter 30, TKS Anti-Ice Fluid Tank Removal/Installation.
 - (3) Remove the fuel line drain hoses.
 - (a) Find the fuel line drain hoses on the forward side of the cargo pod compartment bulkheads.
 - (b) Remove all brackets and hardware that attach the fuel line drain hoses to the bulkheads.
 - (c) Loosen the clamps at the top of the fuel line drain hoses.
 - (d) Remove the fuel line drain hoses from the pod.
 - (4) Remove the fuselage moisture drain lines (Airplanes 20800072 and On and 208B0001 and On).
 - (a) Find the moisture drain lines on the cargo pod bulkheads (Refer to Figure 201, Sheet 2).
 - (b) Loosen the screws and clamps that attach the moisture drain lines to the bulkheads.
 - (c) Move the moisture drain lines down and out of the cargo pod.
 - (5) Find and disconnect the DME and transponder cables from the antennas.
NOTE: Cover assemblies give protection to antenna cable connectors that are on cargo pod bulkheads. Remove the cover assemblies before you disconnect the cables from the antenna.
 - (6) Disconnect the antenna cables at the DME and transponder remote units:
 - (a) Remove the floor cover and pilot's control column cover. Refer to Floor Covering/Control Column Cover - Maintenance Practices.
 - (b) Remove the access panels 211EL, 231BL, 231DL, 232BR, and 232DR. Refer to Chapter 6, Access Plates and Panels Identification - Description and Operation .
 - (c) At the DME antenna and transponder remote unit cables, cut and discard tie wraps.
 - (d) Identify and disconnect the DME antenna cable from the DME remote unit.
 - (e) Identify and disconnect the transponder antenna cable from the transponder remote unit.
 - (7) Find the fuel drain line sleeve on the left side of the cargo pod, a small distance above the main gear.
 - (8) Remove the screws, washers and nuts that attach the fuel drain line sleeve to the cargo pod.
 - (9) Carefully use a non metal scraper to disconnect the fuel drain line sleeve from the cargo pod (on the external area of the cargo pod) and from the fuel drain line cover (on the internal area of the cargo pod).
 - (10) When the sealant bond is broken, carefully pull the fuel drain line sleeve out from the cargo pod and remove it from the airplane.
 - (11) Remove the main gear-to-cargo pod fairings. Refer to Chapter 32, Main Landing Gear - Maintenance Practices.
 - (12) Remove the main gear inner and outer covers from the cargo pod.
 - (13) Loosen the nose gear strut fairing and move it forward.
 - (a) Make sure that the cargo pod does not touch the fairing when it is lowered.
 - (14) Remove the brace cover halves that are on the front of the cargo pod.

- (15) Find and remove the grounding straps at FS 208.00 and 284.00.
- (16) Put two light capacity hydraulic jacks (with jack pads) on the lower surface of the cargo pod, forward of the aft cargo pod door.
- (17) Put one light capacity hydraulic jack (with jack pad) aft of the forward cargo pod door.
- (18) Lift the jacks until the jack pads rest tightly against the lower surface of the cargo pod.
- (19) Remove the screws that attach the cargo pod to the fuselage.
- (20) Lower all the jacks 0.50 inch at the same time.
- (21) Find a fuselage internal structural member at the forward edge of the cargo pod.
- (22) Use a thin nonmetal scrapper and perforate the seal between the fuselage and the pod.
- (23) Use safety wire pliers to twist the two pieces 6 to 8 foot lengths of 0.032 stainless steel lockwire together to make a seal cutting tool.
- (24) Put one end of the seal cutting tool through the perforation.
- (25) With one person in the pod and a second person external, wind the cutter wire at each of the two ends around a block of wood or equivalent tool to serve as handles.
- (26) Cut through the seal.

- (a) Put wood tongue depressors or an equivalent tool between the fuselage and the pod, at 1 to 2 foot increments.

NOTE: This helps to make sure that the seal does not attach again to the pod.

CAUTION: When you lower the cargo pod, make sure that the pod does not touch the fuel drain lines and the fuel drain valve knob on left side of the cargo pod.

- (27) Lower all three jacks at the same time.

NOTE: Antenna cables are to remain in the cargo pod whenever the pod is removed from the airplane.

- (a) Make sure that the DME and the transponder cables that extend up into fuselage are free to move easily out of the fuselage.
- (b) Make sure that the DME and the transponder cables are not damaged.

- (28) If the airplane is to be returned to service without the pod, refer to Modification For Flight Without Pod for further instructions.

B. Install the Cargo Pod (Refer to Figure 201).

- (1) Clean the fuselage skin and the cargo pod at all mating points.
- (2) Put the cargo pod below the fuselage and align the cargo pod with the fuselage attach points.
- (3) Put two light duty hydraulic jacks (with jack pads) under the lower surface of the cargo pod, forward of the aft cargo pod door.
- (4) Put one light duty hydraulic jack (with jack pad) under the lower surface of the cargo pod, aft of the forward cargo pod door.
- (5) Extend the DME and transponder antenna cables up through the holes in the fuselage.
- (6) Apply FS4291 sealant tape to the cargo pod mount flange surface and remove sealant tape paper liner.
- (7) Put personnel in the airplane to move the antenna cables up through the fuselage when you lift the cargo pod to the fuselage.

CAUTION: Make sure that the cargo pod does not touch the fuel drain lines or fuel drain valve knob on the left side of the airplane when you lift the cargo pod to the airplane fuselage.

- (8) Carefully lift the cargo pod to the airplane fuselage with the jacks.
 - (a) Make sure that the attach holes in cargo pod align with the fuselage nut plates.
- (9) Attach the cargo pod to the fuselage with the screws and washers.
- (10) Attach the tops of the fuel line drain hoses, found on the forward side of the compartment bulkheads, to the fuel drain lines.
- (11) Attach the inboard and outboard fuel drain line covers, found at the middle point of the bottom of the fuselage with screws.
- (12) Apply Pro-Seal 890 to the areas that follow:

- (a) The fuel valve sleeve where it connects with the cargo pod (the external area of the pod).
 - (b) The Fuel Drain Line Cover (In The Pod).
 - (c) Seal where pod connects to the fuselage.
- (13) Put the fuel valve sleeve in the pod.
 - (14) Use screws to attach the sleeve to the cargo pod.
 - (15) Use clamps to attach the top of fuel drain line to the fuel drain hoses.
 - (16) Seal the fuel drain line where it goes through the bottom of the cargo pod with Pro-Seal 890.
 - (17) Connect the DME antenna cable to the DME remote unit in the cockpit area.
 - (18) Connect the transponder antenna cable to the transponder remote unit in the cockpit area.
 - (19) Install tie wraps on the DME and transponder cables where appropriate to make sure that they stay in the correct location.
 - (20) Install access panels 211EL, 231BL, 231DL, 232BR and 232DR. Refer to Chapter 6, Access Plates and Panels Identification - Description and Operation.
 - (21) Install the pilot control column cover and the floor covering. Refer to Floor Covering/Control Column Cover - Maintenance Practices.
 - (22) Connect the DME coaxial cable to the DME antenna.
 - (a) Do an operation check of the DME system. Refer to Bendix/King KN 63 DME System.
 - (23) Connect the transponder antenna cables to the correct antennas.
 - (a) Do an operation check of the transponder system. Refer to Garmin GTX-33/GTX-33ES Transponder System.
 - (24) Install the protective cover assemblies around the DME and transponder antennas.
 - (25) Apply Pro-Seal 890 to the brace covers at front of cargo pod, and
 - (26) Use screws to attach the brace covers to the cargo pod.
 - (27) Move the nose gear strut fairing in its position aft against the cargo pod.
 - (28) Tighten the fasteners to attach the nose gear strut fairing to the fuselage.
 - (29) Install the main gear inner and outer covers to the cargo pod.
 - (30) Install the main gear-to-cargo pod fairing. Refer to Chapter 32, Main Landing Gear - Maintenance Practices.
 - (31) Install the TKS anti-ice fluid tank assembly. Refer to Chapter 30, TKS Anti-Ice Fluid Tank. Removal/Installation
 - (32) Spray water along the cargo pod, with a high pressure water hose, where it attaches to the fuselage and check the interior of pod for leaks.

3. Cargo Pod Components Removal/Installation

- A. Remove the Cargo Pod Door (Refer to Figure 202).
 - (1) Open the cargo pod door.
 - (2) Remove the screws, washers and nuts that attach the door and hinges to the cargo pod.
 - (3) Remove the door.
- B. Install the Cargo Pod Door (Refer to Figure 202).
 - (1) Put the door to the cargo pod and align the hinge holes to the cargo pod attach points.
 - (2) Install the screws, washers and nuts that attach the door to the cargo pod.
- C. Remove the Door Hinges (Refer to Figure 202).
 - (1) Remove the cargo pod door.
 - (2) Remove the screws and washers that attach the hinge to the door, and remove the hinge.
- D. Install the Door Hinges (Refer to Figure 202).
 - (1) Put the hinge on the door and install the washers and screws.
 - (2) Put the hinge on the cargo pod and attach the screws, washers and nuts.
- E. Remove the Door Latch (Refer to Figure 202).
 - (1) Open the cargo door.

(2) Remove the pin from the handle, and slide the block and shaft out of the door.

F. Install the Door Latch (Refer to Figure 202).

NOTE: If door bushing assembly and washer were removed, bond bushing assembly and washer with Type I, Class B adhesive. Refer to Chapter 25 Cargo Pod – Approved Repairs.

(1) Put the washers on the shaft.

NOTE: Install the washers as necessary to bring the exterior surface of door flush with the exterior surface of the pod. Do not use more than three washers for each screw.

NOTE: If additional adjustment is needed, loosen the screw and nut that attach the block to the shaft. Slide the block in the desired direction, and tighten the block on the shaft with a screw and a nut.

(2) Place the spring washer on the shaft.

(3) Place the shaft through the door.

(4) Place the handle on the shaft and attach it with a pin.

G. Remove the Cargo Pod Door Lock Assembly.

(1) Unlock and open the door.

(2) Bend lockwasher tab away from the nut.

(3) Remove the nut, lockwasher, cam, nut and lockwasher from the back of the lock assembly.

(4) Remove the key lock assembly from the door.

H. Install the Cargo Pod Door Lock Assembly.

(1) Position lock assembly through opening in front of door.

(2) Assemble the lock as follows:

(a) Install lockwasher and nut on the lock assembly; tighten nut. To prevent nut from loosening, bend lockwasher tab against one flat of the nut.

CAUTION: Do not use too much Loctite 242 adhesive or it could get into the lock and ruin it.

(b) Put one drop of Loctite 242 on each of the nut threads.

(c) Install cam, lockwasher and nut on the lock assembly; tighten nut.

(3) Turn the key and lock to make sure that the cam engages and locks the door correctly.

4. Modification for Flight Without the Cargo Pod

NOTE: You must complete this procedure if the cargo pod has been removed and the airplane is returned to service without the pod.

A. Modification Procedures (Refer to Figure 203).

(1) Install the screws and washers on all the fuselage nutplates where the cargo pod attaches to the fuselage.

(2) Turn both fuel selectors, found in the overhead console, to the OFF position.

(3) Find the fuel drain valve knob below the left main gear.

(4) Pull the fuel drain valve knob out to drain the fuel reservoir.

(5) Remove the screws that attach the inboard fuel drain line cover to the fuselage.

(6) Remove the cover to get access to the drain valves, lines and reservoir.

(7) Disconnect the fuel drain line fitting at the fuel drain valve.

(8) Unscrew and remove the insert from the fuel drain valve.

(9) Disconnect the cable from the fuel drain valve.

(10) Loosen the clamp that attaches the cable to the fuselage.

(11) Disconnect the pump seal fuel drain lines from the elbow fittings.

(12) Remove the drain lines, fuel drain valve knob, cable and the outboard fuel drain line cover as one assembly.

NOTE: On Airplanes 20800001 thru 20800086, inboard and outboard fuel drain line covers were assembled as a single unit. To access the drain valve, remove all the screws and lower the covers away from the fuselage being careful not to bend or break the drain lines and cable.

One-piece covers on Airplanes 20800001 thru 20800086 can be replaced with the two-piece configuration, but when you order spares, the covers must be replaced in pairs.

- (13) Remove the skin panel from the bottom of the fuselage to get access to the fuel reservoir.
- (14) Disconnect the upper pump seal fuel drain line from the adapter.
- (15) Remove the screws and washers that attach the access cover to the reservoir.
- (16) Remove the access cover from the airplane.
- (17) Cut the safety wire and remove the drain valve, O-ring, washer and nut from the access cover.
 - (a) Discard the O-ring.
- (18) Install the special drain valve (Part Number 967B-5), new O-ring, washer and the nut in the access cover.
- (19) Put the access cover (with new gasket) in its position on the reservoir.
- (20) Use screws to attach the access cover to the reservoir.
- (21) Install the pump seal drain line to the adapter.
- (22) Apply sealant tape to the skin panel, remove the paper liner, and install skin panel to fuselage.
- (23) Use screws to attach the skin panel to the fuselage.
- (24) Use plug buttons to close out the antenna cable holes and fuel line hole in the fuselage skin.
- (25) Refer to the applicable Chapter 34 transponder section for procedures to install the transponder antenna(s) on the bottom of the fuselage
- (26) Install cockpit access panels 211EL, 231BL, 231DL, 232BR and 232DR. Refer to Chapter 6, Access Plates and Panels Identification - Description and Operation.
- (27) Clean the sealant from the fuselage along the cargo pod attach points.
- (28) Make a patch plate with a 1.28 inch diameter hole to accommodate the drain valve.
- (29) Attach the patch plate to the airplane with screws.

5. Reinstalling the Cargo Pod After Flight Without the Cargo Pod

NOTE: This procedure must be used after the airplane has been returned to service without the cargo pod, and the cargo pod is being reinstalled.

- A. Procedures For Reinstalling the Cargo Pod After Flight Without the Pod (Refer to Figure 203).
 - (1) Turn both fuel tank selectors, found in the overhead console, to the OFF position.
 - (2) Push the fuel valve lever up, and rotate it 90 degrees to drain the fuel from fuel reservoir.
 - (3) Remove the patch plate from the underside of the fuselage.
 - (4) Remove the fuselage skin panel from the underside of the fuselage.
 - (5) Disconnect the pump seal fuel drain line from the adapter.
 - (6) Remove the screws and washers that attach the access cover to the fuel reservoir.
 - (7) Remove and discard the gasket from the access cover.
 - (8) Remove the drain valve, O-ring and nut from the access cover.
 - (a) Discard the O-ring.
 - (9) Install the remotely-operated fuel drain valve, new O-ring and nut on the access cover.
 - (10) Safety wire the remotely-operated fuel drain valve to the access cover.
 - (11) Install the access cover to the fuel reservoir with the new O-ring.
 - (12) Turn both of the fuel tank selectors, found in the overhead console, to the ON position and check for leaks.
 - (13) Install the upper pump seal drain valve line to the remotely-operated fuel drain valve.
 - (14) Apply sealant tape to the skin panel, remove the paper liner, and install skin panel to fuselage.
 - (15) Install seal plug buttons in the fuselage skin drain holes as necessary. Refer to Table 201 for exact locations.

Table 201. Fuselage Plug Locations

MODEL	FS LOCATION	BL LOCATION	QUANTITY
-------	-------------	-------------	----------

208 Only	115.88	0.00	1
208 and 208B	116.65	9.35	2
208 and 208B	164.85	8.60 and 19.60	4
208 Only	192.80	0.25 and 15.75	3
208 Only	201.20	0.00	1
208 Only	209.60	15.75	2
208B Only	212.80	0.25 and 15.75	3
208B Only	221.20	0.00	1
208B Only	257.60	15.75	2
208 Only	283.40	15.75	2
208 Only	285.05	14.25	2
208B Only	331.40	15.75	2

(16) Apply Pro-Seal 890 to the surfaces that connect the outboard fuel drain line cover.

NOTE: On Airplanes 20800001 thru 20800085, the inboard and outboard fuel drain line covers were assembled as a single unit. On this fuel drain line cover, it will be necessary to connect the drain line and cable before you attach the fuel drain line cover to the fuselage.

(17) Put the outboard fuel drain line cover in its position on the fuselage.

(18) Install the screws that attach the outboard fuel drain line cover to the fuselage.

(19) Connect the cable to the drain valve.

(20) Connect the drain line to the drain valve.

(21) Attach the cable to the fuselage skin with a clamp.

(22) Connect the lower pump seal drain line to the elbow.

(23) Apply sealant to the surface that connects the inboard fuel drain line cover to the fuselage.

(24) Install the screws that attach the inboard fuel drain line cover to the fuselage.

(25) Check the fuel drain valve knob for proper operation and correct installation as follows:

(a) Pull the drain valve knob out and make sure that fuel flows through the fuel drain lines.

(b) Push the drain valve knob in and make sure that no fuel flows through fuel drain lines

(26) Refer to the applicable Chapter 34 transponder section for procedures to remove the transponder antenna(s) from the bottom of the fuselage.

(27) Refer to the applicable Chapter 34 transponder section for procedures to install the transponder antenna(s) on the bottom of the pod.

(28) Install the protective cover assemblies over the antenna cables.

NOTE: Seal the antenna holes in the fuselage with fuselage plugs.

Figure 201 : Sheet 1 :

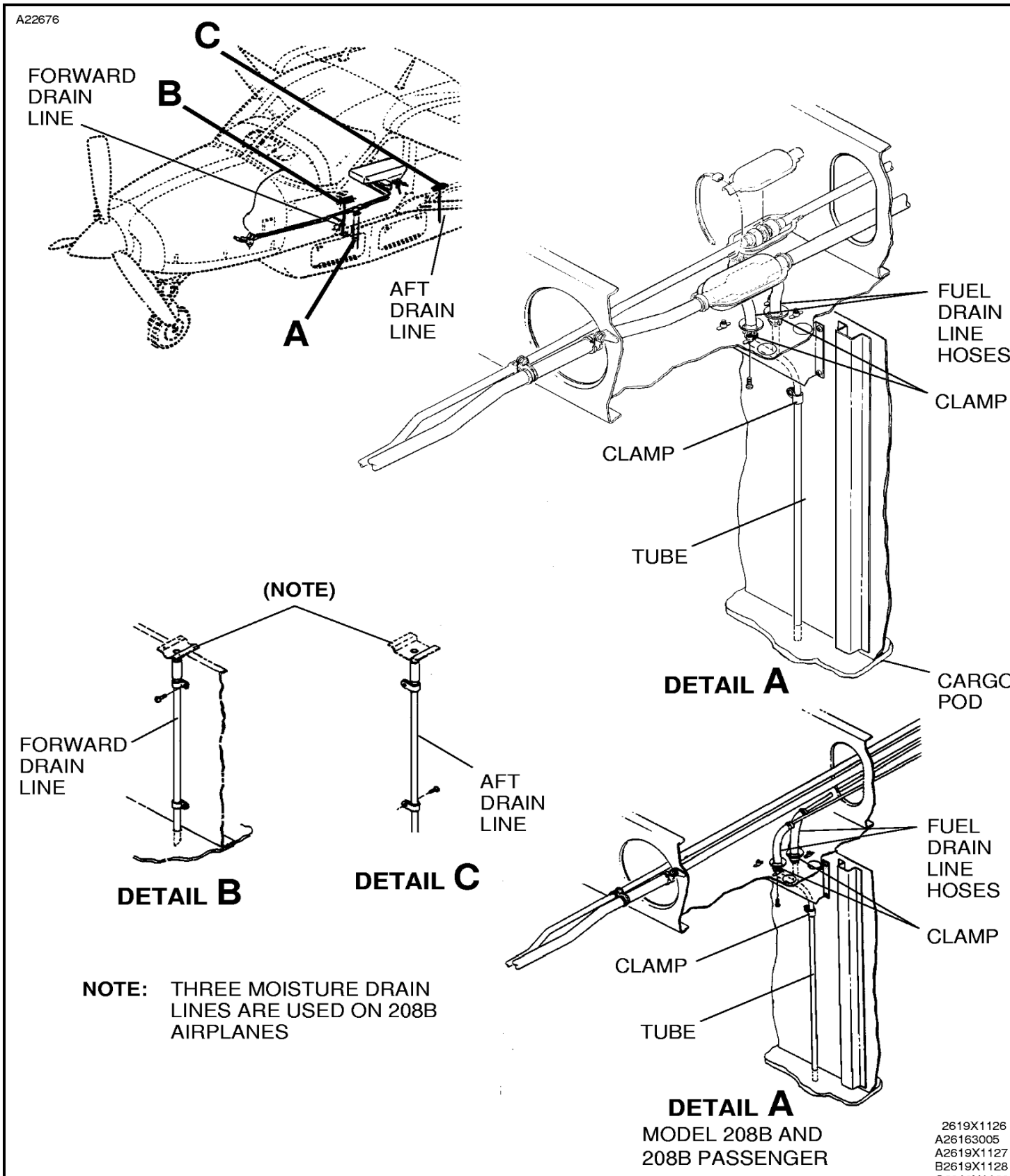

Figure 201 : Sheet 2 :

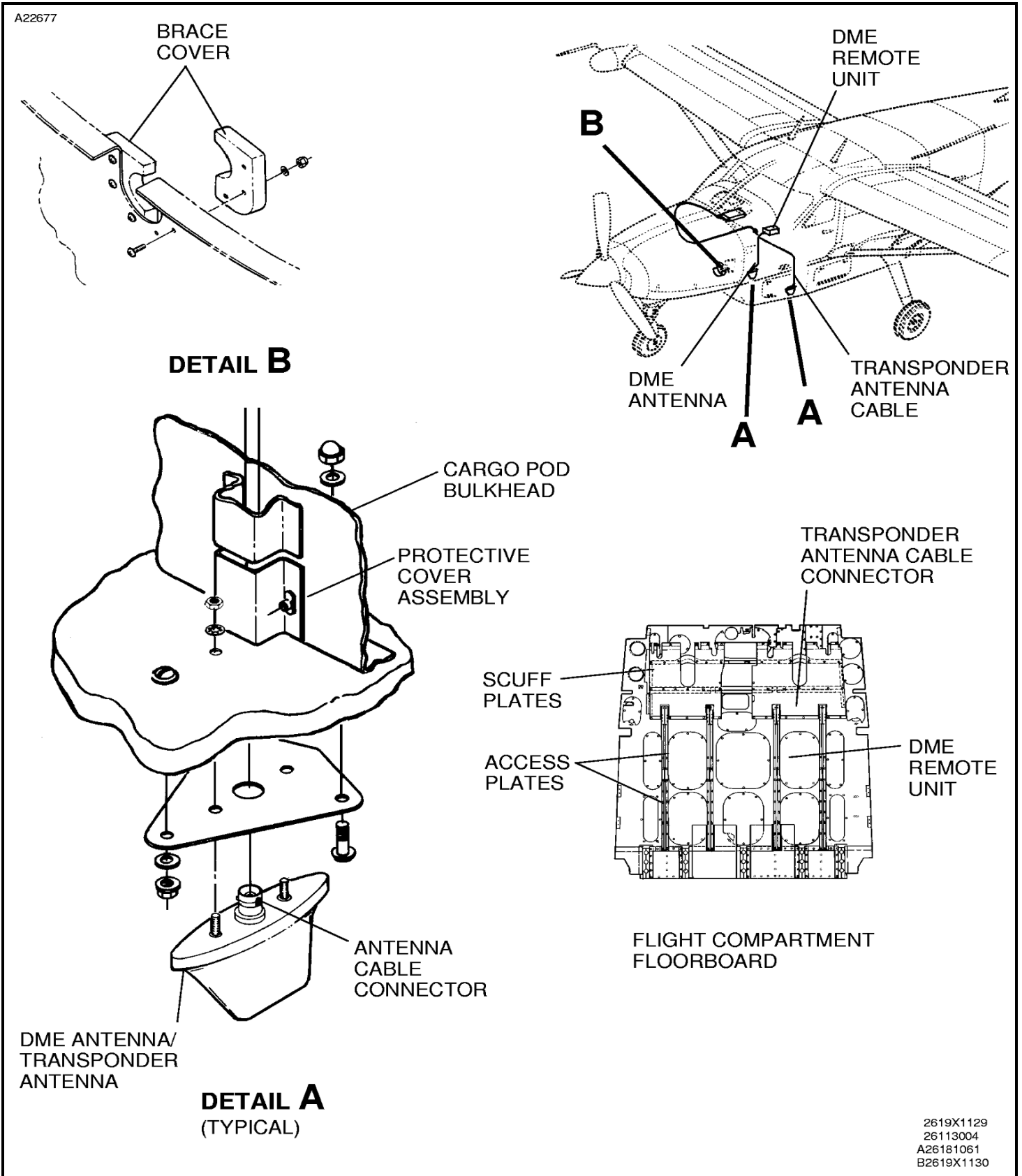
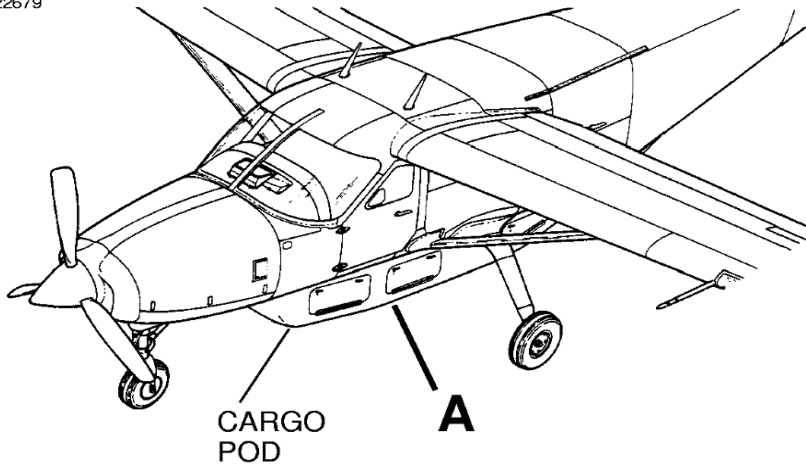
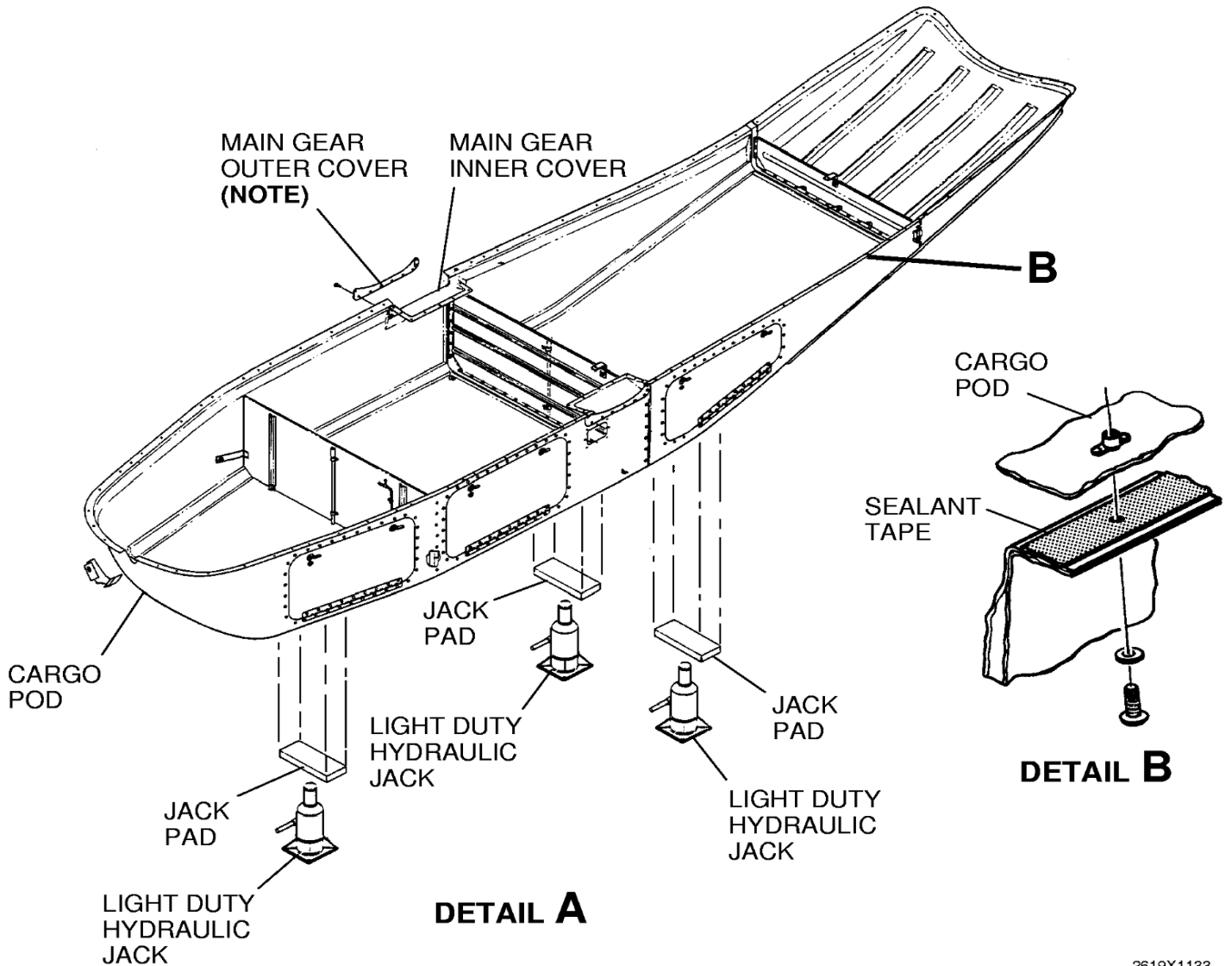

Figure 201 : Sheet 3 :

A22679



NOTE: AIRPLANES 20800001
THRU 20800139



MODEL 208 AND 208 CARGOMASTER

2619X1133
A26124002
B26191115

Figure 201 : Sheet 4 :

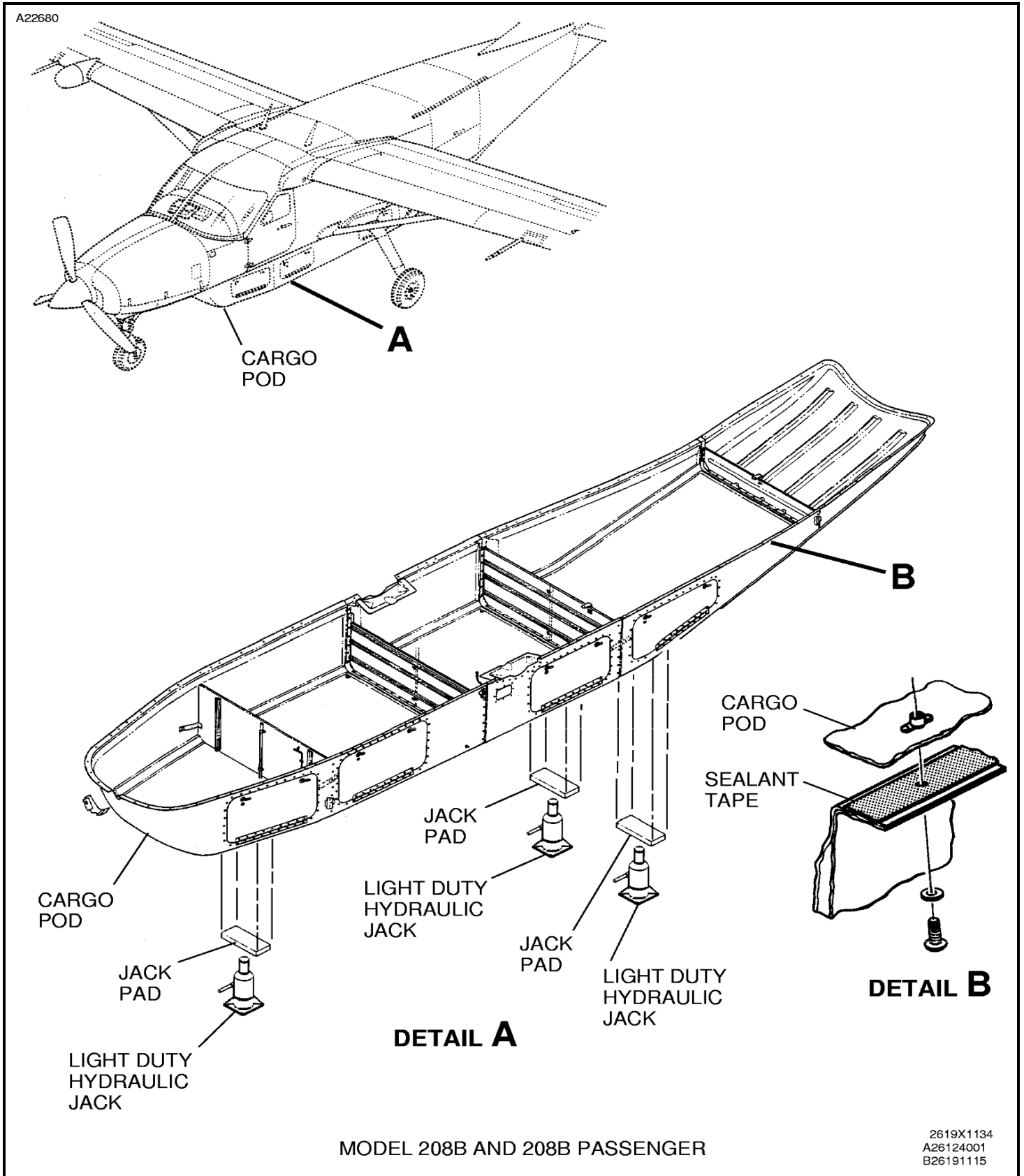
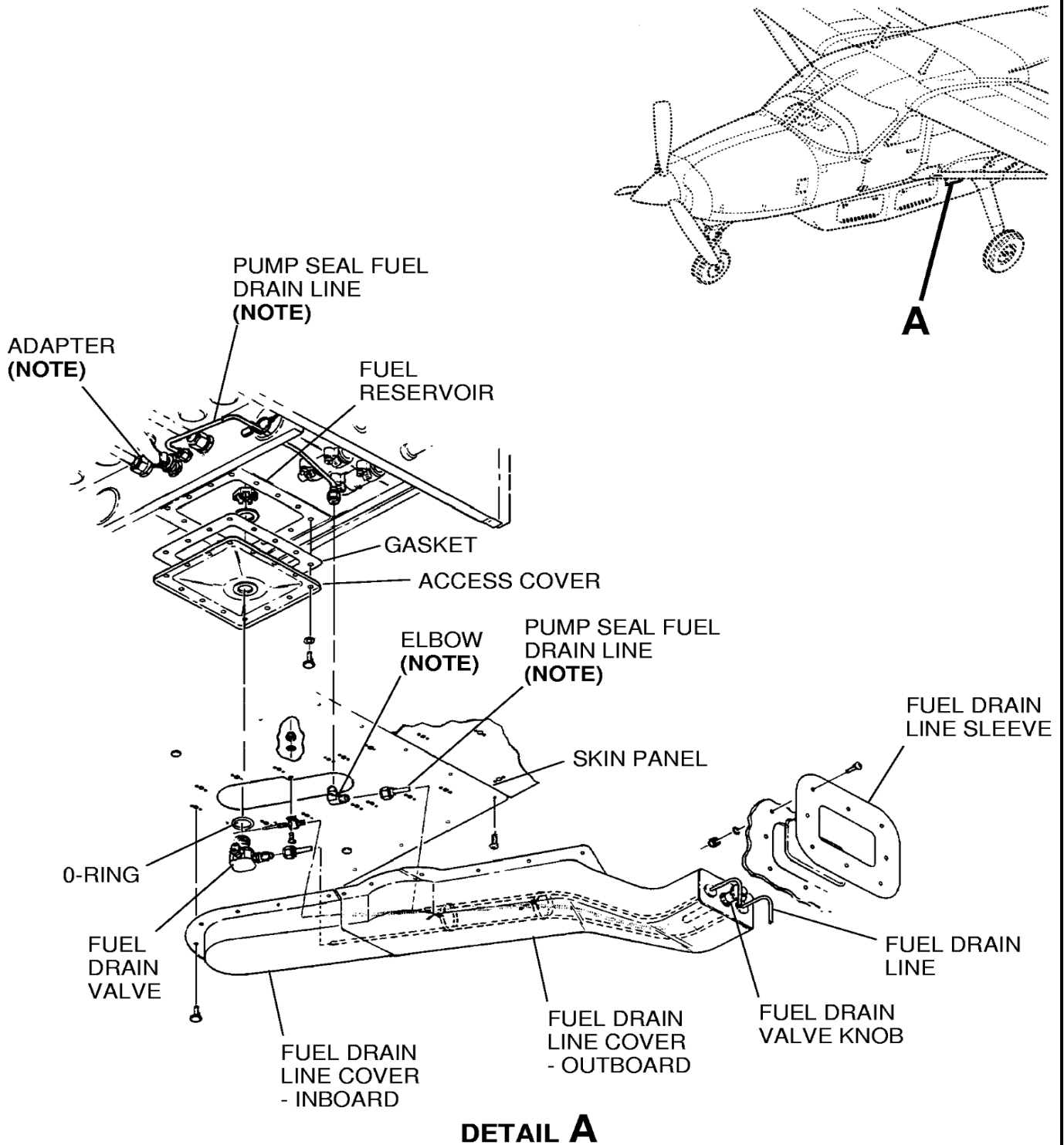

Figure 201 : Sheet 5 :

A22681



NOTE: THESE PARTS ARE NOT USED WHEN THE ALTERNATE (AIRBORNE 2G6-8) FUEL PUMP IS INSTALLED.

2619X1131
A2619X1132

Figure 202 : Sheet 1 : Cargo Pod Components Installation

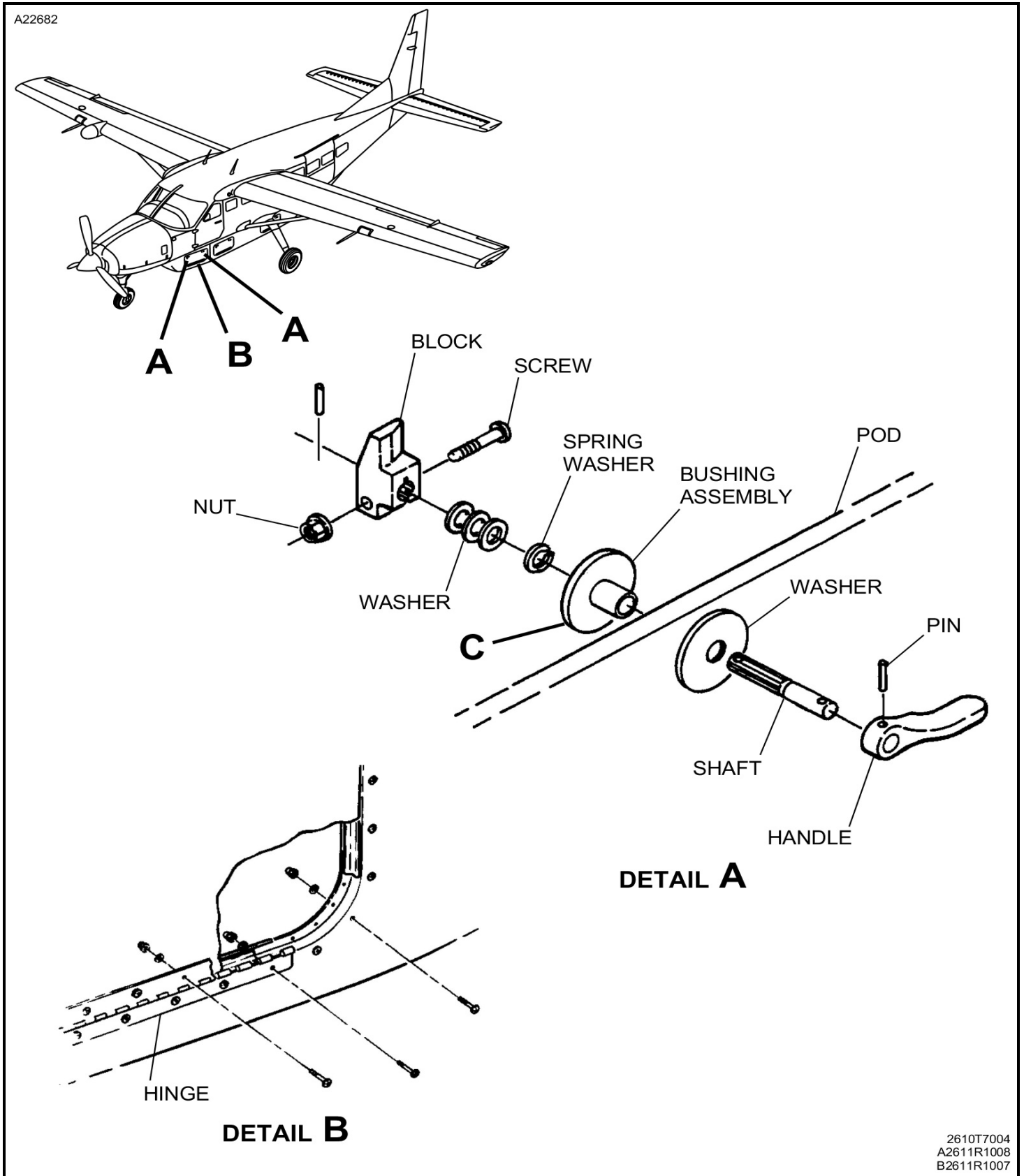
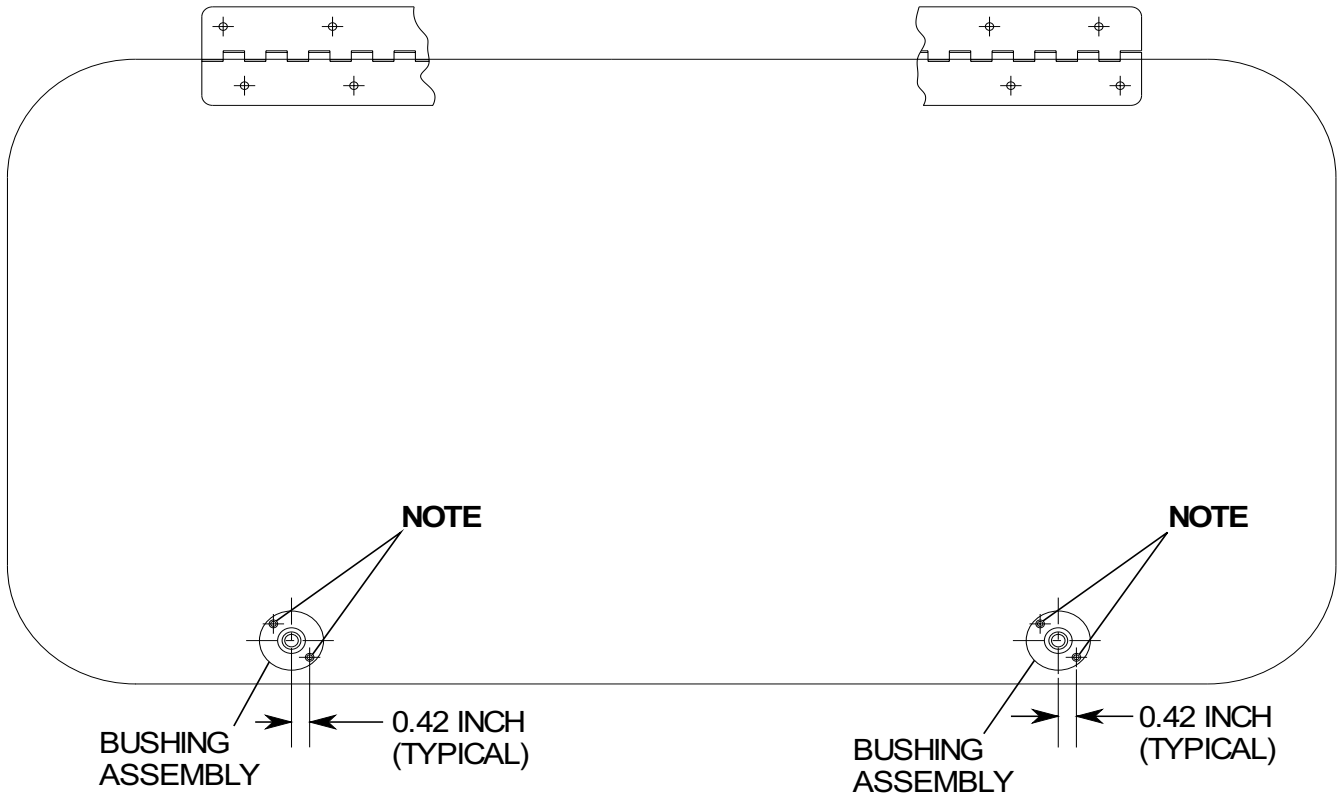

Figure 202 : Sheet 2 : Cargo Pod Components Installation

A99678



DETAIL C
VIEW LOOKING AT INSIDE SURFACE OF DOOR

NOTE: POSITION OF THE CAM BLOCK STOPS IN THE BUSHING ASSEMBLY

C2601T218

Figure 203 : Sheet 1 : Preparation for Flight Without Cargo Pod

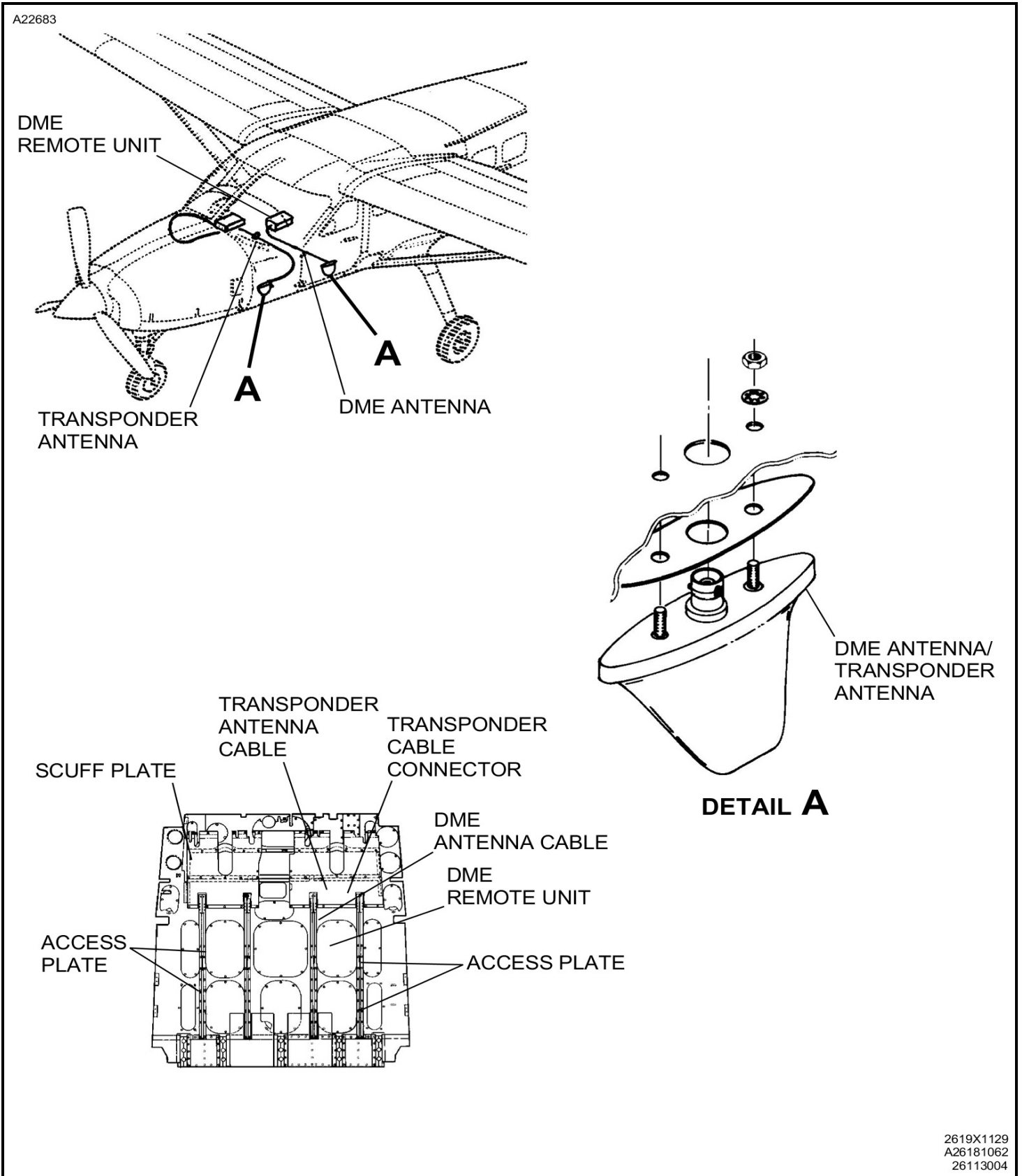

Figure 203 : Sheet 2 : Preparation for Flight Without Cargo Pod

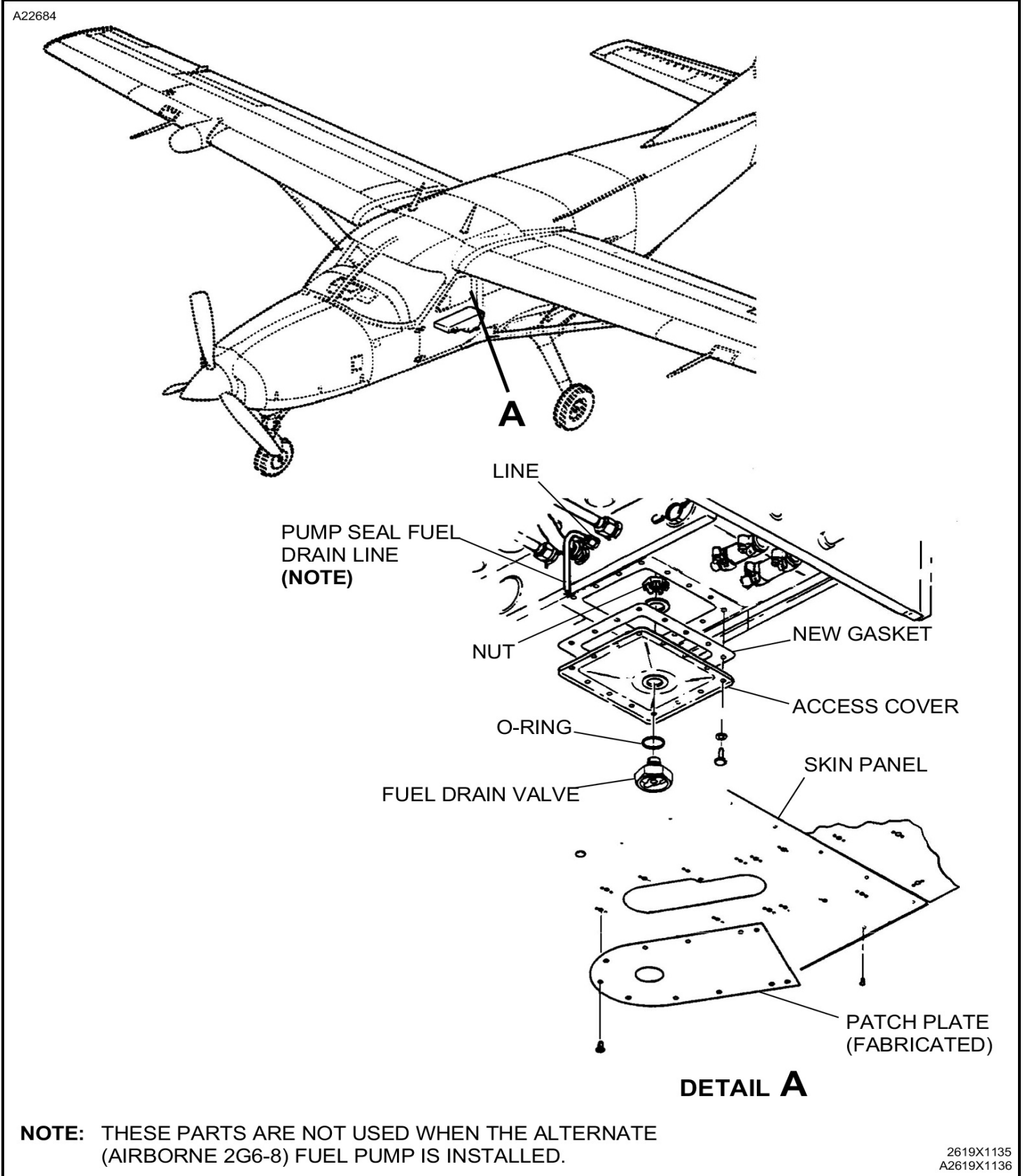

Figure 2 : Sheet 1 : Model 208 Floorboard Access Plates/Panels Identification

